



MARIANO MARCOS STATE UNIVERSITY

Bids and Awards Committee

INVITATION TO MAKE AN OFFER: Negotiated Procurement

2022-028-3

THE PROJECT: Refurbishment of Student Council Office, MMSU, City of Batac
Number of Working Days: 60 calendar days
ABC: P256,368.42

1. The Mariano Marcos State University (MMSU), with offices at Quiling Sur, City of Batac, Ilocos Norte, invites the public to make an offer to furnish all labor, materials, tools and equipment necessary and proper for the implementation of the above Project as per approved designs, plans and drawings.
2. This process is in accordance with Section 53 of R.A. 9184, the Government Procurement reform Act and Section 53.9 of the Implementing Rules and Regulations where interested and qualified contractors are to submit proposals.
4. The offer must be in writing submitted at the address below not later than **5 days** together with the following documents:
 - a) The amount of the offer in writing duly signed by the person making the offer, indicated in numbers and figures.
 - b) The particulars of the offer as to labor, materials, tools, equipment and other work details.
 - c) Documents in support of the legal, technical and financial capability of the person making the offer, which documents shall be confirmed and verified (3 copies).
5. It is understood that any offer may be accepted or rejected, or the process invalidated, at any time prior to contract award, without liability to anyone.
6. Documents for this procurement may be secured from the MMSU BAC Secretariat at the address below or downloaded from the MMSU website or from the Philippine Government Electronic Procurement System (PhilGEPs) website.
7. For questions and inquiries, please write or email the University President, thru the BAC Chair, at the address indicated below.

Mariano Marcos State University
Quiling Sur, City of Batac
www.mmsu.edu.ph

November 23, 2022

NATHANIEL R. ALIBUYOG
BAC CHAIR

Received: _____ Received: _____ Received: _____

PROJECT INFORMATION DOCUMENT

Project Title : Refurbishment of Student Council Office
Project Location : MMSU-COE, City of Batac, Ilocos Norte

Page 1 of 3

GENERAL INSTRUCTION

The project calls for the furnishing of all materials, labor, tools and equipment needed for the above-mentioned project. The proposed undertaking shall be done in strict conformity with the plans, drawings and other details, as well as the specifications and this Project Information Document prepared and approved for this project.

If the bidder finds disparity in the plans and specifications in relation to the actual situation, the bidder must inform the concerned PPDO Technical Staff for appropriate clarifications. Subsequently, provision of all utilities and amenities needed in the execution of the work such as electrical system, water supply system, construction of temporary enclosure, location of construction signages, accessibility to and from the construction site, storage areas for construction materials and other needed appurtenances prior to, during and after the construction activities must be thoroughly considered as part of this contract.

It also calls for the employment of the required manpower with the appropriate skills and expertise to undertake the specific items of work to enable the contractor to produce and deliver to the satisfaction of the Owner the needed services and output required of this undertaking. In addition, the contractor shall have adequate and readily available construction tools and equipment to be utilized during the construction activities. It is also must as it is necessary that the contractor shall have regularly at the site a qualified project Engineer to administer strictly the implementation of the project, including maintaining a log book of construction activities, as well as receiving authorized University Officials and Inspectors.

Unless specifically indicated in any of the Contract Documents for this project, all items of work under this Contract will be provided with complete materials and labor.

The project covers the Refurbishment of the COE-SC office. The contractor shall ensure that the construction activities must not interfere, obstruct and disturb any on-going operation of the other areas in the site.

The prospective bidders shall submit a bid proposal for the above-mentioned project with the following scope/item of work:

1. **ROUGHING WORKS** - This includes the demolition (provision of access door and for the replacement of the ceiling) and the clearing and cleaning of the area.
2. **DRY WALL PARTITION WORKS**- This includes the provision of a new partition wall for the stock room extension of the student council office. Use gypsum board $\frac{1}{2}$ " thk and 35mm x 64mm x 0.5mm thk metal stud frame.

PROJECT INFORMATION DOCUMENT

Project Title : Refurbishment of Student Council Office
Project Location : MMSU-COE, City of Batang, Ilocos Norte

Page 2 of 3

3. **CEILING WORKS** – This includes the replacement of the existing ceiling of the student council office. New material should follow what is in the plan or specifications.
4. **PAINTING WORKS** – This includes the painting of the interior and exterior of the student council office wall and ceiling.
5. **DOORS AND WINDOWS** – This includes fabrication, delivery and installation of required number, size and specification included in the plans.
6. **ELECTRICAL WORKS** – This includes the replacement of electrical lines and fixtures following the given plans and specification.
7. **OCCUPATIONAL SAFETY AND HEALTH** – This includes the provision of basic PPE, first aid kit and warning signage as per DOLE Department Order No 13 series 1998.

SUPPLEMENTARY NOTES

- A. All other items or scope of works not mentioned in this document but shown and/or indicated in the plans, drawings and specifications, and very vital for the completion of the project the contractor shall likewise furnish all materials, labor and equipment necessary to complete the same.
- B. In case that conflicts arise among specifications and quality of materials, installation procedure and in the plans and drawings as well as in the other contract documents before and during the implementation stage, the same should be referred to the end-user for proper resolution of the said conflicts.
- C. Where the above-mentioned items or scope of works require the approval of the quality and design of the materials to be used or their testing before they are installed, embedded in concrete or enclosed with specified covering materials, the contractor shall secure from the University clearance or permission related hereto.
- D. The Contractor shall submit shop drawings to PPDO for all applicable Scope/Item of work and secure approval prior to commencing any work. Approved shop drawings shall form part of the as-built plans.
- E. After all the works have been completed, the surrounding immediate areas affected in the prosecution of the project shall be cleaned and cleared of all excess materials and debris, temporary structures, facilities and utilities used during the construction period. Before turning over the contract to the Owner, the Contractor shall test the electrical system to the satisfaction of the owner.

PROJECT INFORMATION DOCUMENT

Project Title : Refurbishment of Student Council Office
Project Location : MMSU-COE, City of Batac, Ilocos Norte

Page 3 of 3

- F. The Contractor shall submit to PPDO Electrical and Mechanical plan after all works have been completed. Architectural, Structural and other as-built plans shall also be submitted whenever there is a difference from the original plan.
- G. Time is a very important factor in the implementation of this project and as such, all works indicated in the plans, specifications and in this document shall be completed within **60 calendar days** from receipt of the Notice to Proceed.
- H. The Approved Budget for the Project to be bid is **Two Hundred Fifty-Six Thousand and Three-Hundred Sixty-Eight Pesos and Forty-Two Centavos (Php. 256,368.42).**

Prepared by:

KENNETH HEDRA
Instructor I

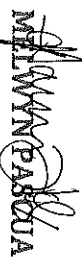
MELWYN PASSUA
Instructor I

Checked/Reviewed by:

AIDA V. CABANG
Chief, Physical Planning Section

ROMEO R. BULDUIAO
Director, PPDO

Republic of the Philippines
MARIANO MARCOS STATE UNIVERSITY
 PHYSICAL PLANNING AND DEVELOPMENT OFFICE
 City of Batac, 2906, Ilocos Norte

Refurbishment of Student Council Office
 (MMSU-Batac Campus, City of Batac, Ilocos Norte)

BILL OF QUANTITIES			
Item No.	Description	Quantity	Unit
I	Roughing Works	1.00	ls.
II	Drywall Partition		
	Gypsum Fire Retardant Board, 1.2 m x 2.4 m x 1/2"	8.00	pcs.
	Metal Furring, 3m	25.00	pcs.
	Metal Screw, 1"	100.00	pcs.
III	Ceiling Works		
	Gypsum Fire Retardant Board, 1.2 m x 2.4 m x 1/2"	20.00	pc
	Metal Furring, 3m	62.00	pc
	Carrying Channel	20.00	pc
	Hanger Bars/Rod	54.00	pc
	Channel Clip	324.00	pc
	Wall Angle	13.00	pc
	Rivets	756.00	pc
	Metal Screw, 1"	216.00	pc
IV	Painting Works		
	Wall Painting		
	Paint Thinner	5.00	bottles
	Sand Paper #80	10.00	pcs
	Roller Brush with Pan	2.00	pcs
	4" Paint Brush	3.00	pcs
	Patching Compound	5.00	gals
	Semi-Gloss Latex	8.00	gals
	Ceiling Painting		
	Paint Thinner	5.00	bottles
	Sand Paper #80	10.00	pcs
	Roller Brush with Pan	2.00	pcs
	4" Paint Brush	3.00	pcs
	Patching Compound	3.00	gals
	Semi-Gloss Latex	5.00	gals
V	Doors and Windows		
	0.9m x 2.1m Panel Door (includes door accessories)	2.00	sets
	powder coated aluminum window, sliding (150cm x 200cm)	9.00	sq.m.
	For door frame finish		
	Cement	2.00	bags
	Sand	0.50	cu.m.

VI	Electrical Works			
	Wires			
	2.0 mm2 thhn wires	1		box
	3.5 mm2 thhn wires	1		box
	5.5 mm2 thhn wires	75		m
	14 mm2 thhn wires	20		m
	Conduit			
	1/2" PVC PIPES	20		pcs
	3/4" PVC PIPES	5		pcs
	Panel Board			
	6 Holes Center Main	1		PC
	ECB nema 3R	2		PCS
	CIRCUIT BREAKERS:			
	20 AT Bolt On CB	3		PCS
	60 AT Bolt On CB	1		PCS
	15 AT Bolt On CB	1		PCS
	BOXES			
	junction box	12		pcs
	utility box	9		pcs
	SWITCHES AND OUTLETS			
	2-2GANG SWITCH	2		SETS
	1-GANG SWITCH	1		SETS
	2-2GANG CONVENIENTS OUTLETS	9		SETS
	OTHERS			
	ELECTRICAL TAPE	3		PCS
	BUTANE GAS	2		PCS
	Lighting Fixtures	3.00		sets

GROUND FLOOR

Scale 1:1

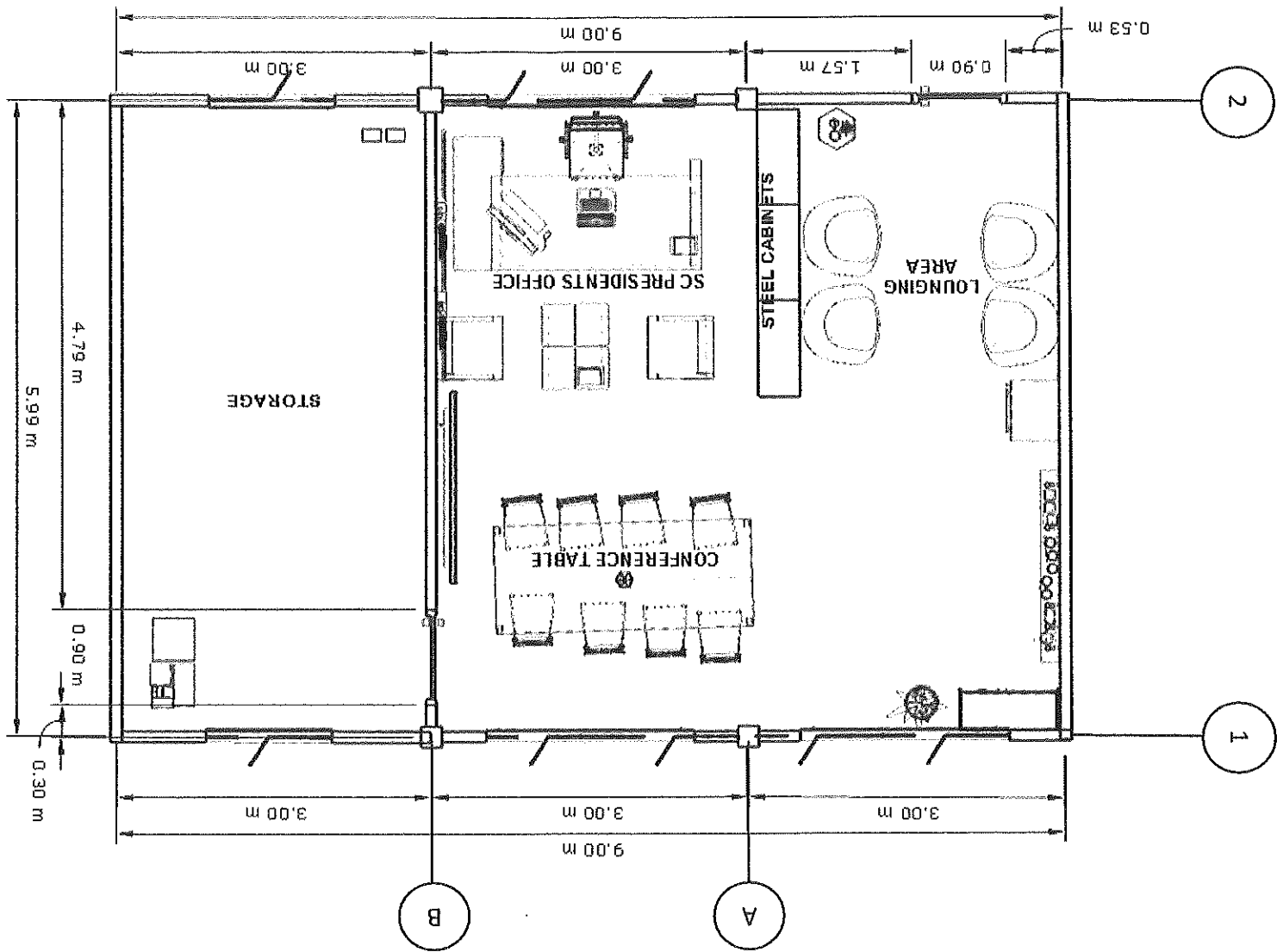

LEFT ELEVATION

Scale 1:1

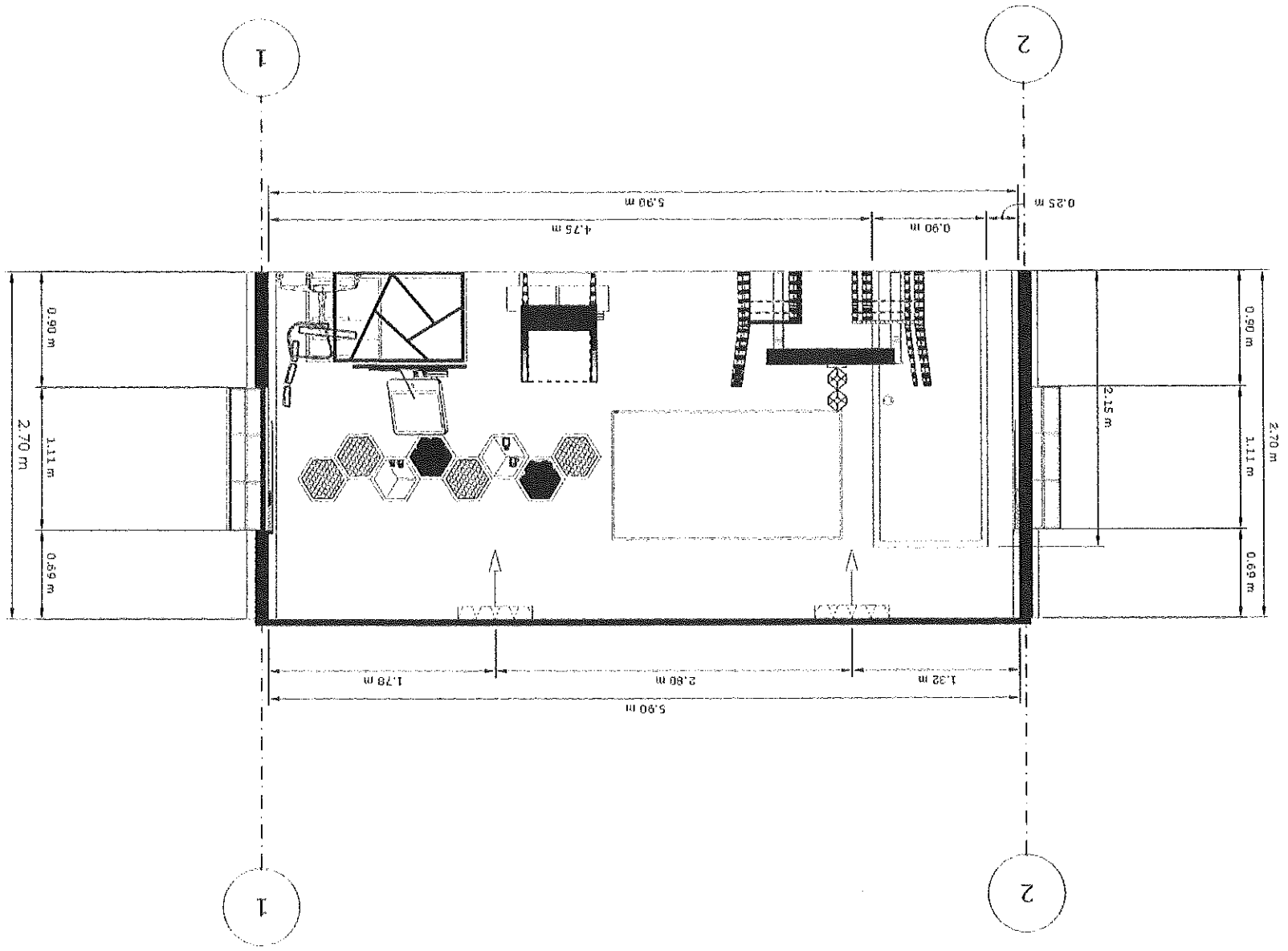



PHYSICAL PLANNING AND DEVELOPMENT OFFICE
 ROOM 202 FERN HALL, HERRERA WALK, STATE UNIVERSITY
 LOS BAÑOS, QUEZON PROVINCE, PHILIPPINES
 TEL: (02) 773-2181

MLYAN P. PASQUA
 ELECTRICAL ENGINEER

PROJECT NO.:
 PROJECT NAME:
 PROJECT LOCATION:
 PROJECT DATE:

COMPILED BY:
 CHECKED BY:
 APPROVED BY:
 DATE OF APPROVAL:
 PROJECT NO.:
 PROJECT NAME:
 PROJECT LOCATION:
 PROJECT DATE:

SHIRLEY O. ASSUPIS
 ELECTRICAL ENGINEER

PROJECT NO.:
 PROJECT NAME:
 PROJECT LOCATION:
 PROJECT DATE:

PROJECT NO.:
 PROJECT NAME:
 PROJECT LOCATION:
 PROJECT DATE:

E-1 ELECTRICAL SYMBOLS

- 30W LED LIGHTING OUTLET
- 10W LED LIGHTING OUTLET
- 6W LED LIGHTING OUTLET
- SPECIAL LED LIGHTING OUTLET
- WALL LED LAMP
- DUPLEX CONVENIENCE OUTLET
- WEATHERPROOF CONVENIENCE OUTLET
- CABLE TV OUTLET
- PHONE/INTERNET OUTLET
- SPECIAL PURPOSE OUTLET
- WATER HEATER OUTLET
- RANGE HOOD OUTLET
- NEMA 3R ENCLOSURE
- W/ 30A CIRCUIT BREAKER

- GENERAL NOTES AND SPECIFICATIONS
- All works herein shall be done with the direct supervision of a licensed electrical practitioner REE/RME. The applicable provisions of the latest edition of the PEC, the rules and regulation of the local enforcing authority, and the requirements of the local power companies.
 - All feeders shall be installed as indicated on plans, branch circuit homerun wires shall be installed in individual homerun conduits.
 - The mounting heights of wiring devices shall be as follows:
 - a. Light switches - 1.4m above finished floor
 - b. Convenience Outlet - 0.4m above finished floor
 - c. Telephone Outlet - 0.4m above finished floor
 - d. Panel Board & Enclosure - 1.8m above finished floor to center of main CB
 - No termination/splicing shall be done inside the conduit plans. Conduit shall be embedded in wall, floor, or ceiling

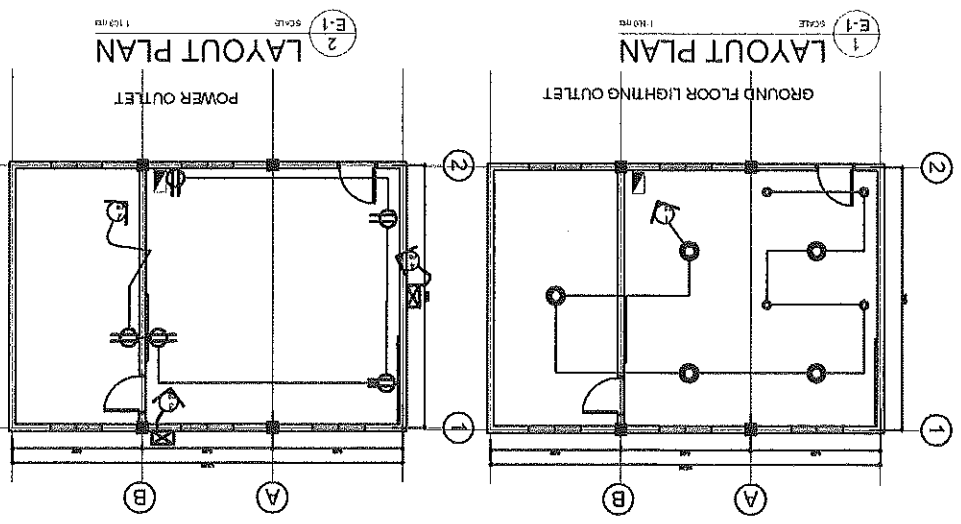

E-1 SINGLE LINE DIAGRAM

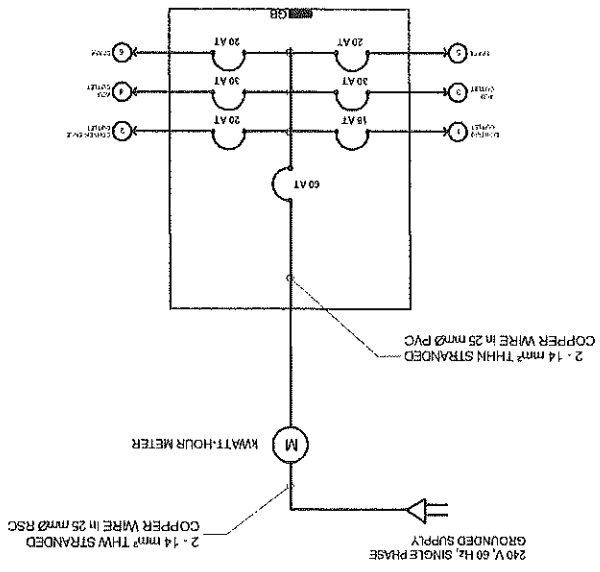

E-2 SCHEDULE OF LOADS

CMT. NO.	LOAD DESCRIPTION	VA LOAD	CURRENT	CIRCUIT BREAKER		CONDUCTOR		CONDUIT		
				AT	POLE	AF	SIZE		TYPE	DIAMETER
1	5 - 30W LED Light Outlet & 4 - 6W LED Light Outlet	174	0.76	15	2	60	2 - 2.0mm² & 1 - 3.5mm²	THHN	25 mm	PVC
2	5 Sets - 180VA Convenience Outlets	900	3.91	20	2	60	2 - 3.5mm² & 1 - 3.5mm²	THHN	25 mm	PVC
3	1 Sets - ACU Outlet	1840	8.00	30	2	60	2 - 5.5mm² & 1 - 3.5mm²	THHN	25 mm	PVC
4	1 Sets - ACU Outlet	1840	8.00	30	2	60	2 - 5.5mm² & 1 - 3.5mm²	THHN	25 mm	PVC
5	Spare	1500	6.52							
6	Spare	1500	6.52							
TOTAL		7754	33.7130							

FEEDER CONDUCTORS & MAIN SERVICE EQUIPMENT
 IFL = 17.71A (80%) + 16A (100%) + 8A (25%) = 32.17 A
 USE: 2 - 14mm² THW COPPER WIRE IN 25 mmØ RSC

SERVICE EQUIPMENT
 IFL = 17.71A (80%) + 8A (100%) + 8A (250%) = 42.17 A
 USE: 60A T 2-POLE, 230V, 60HZ CIRCUIT BREAKER

ACS

PERSPECTIVE

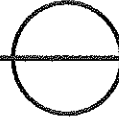

MAIN ROOM

ACS

PERSPECTIVE

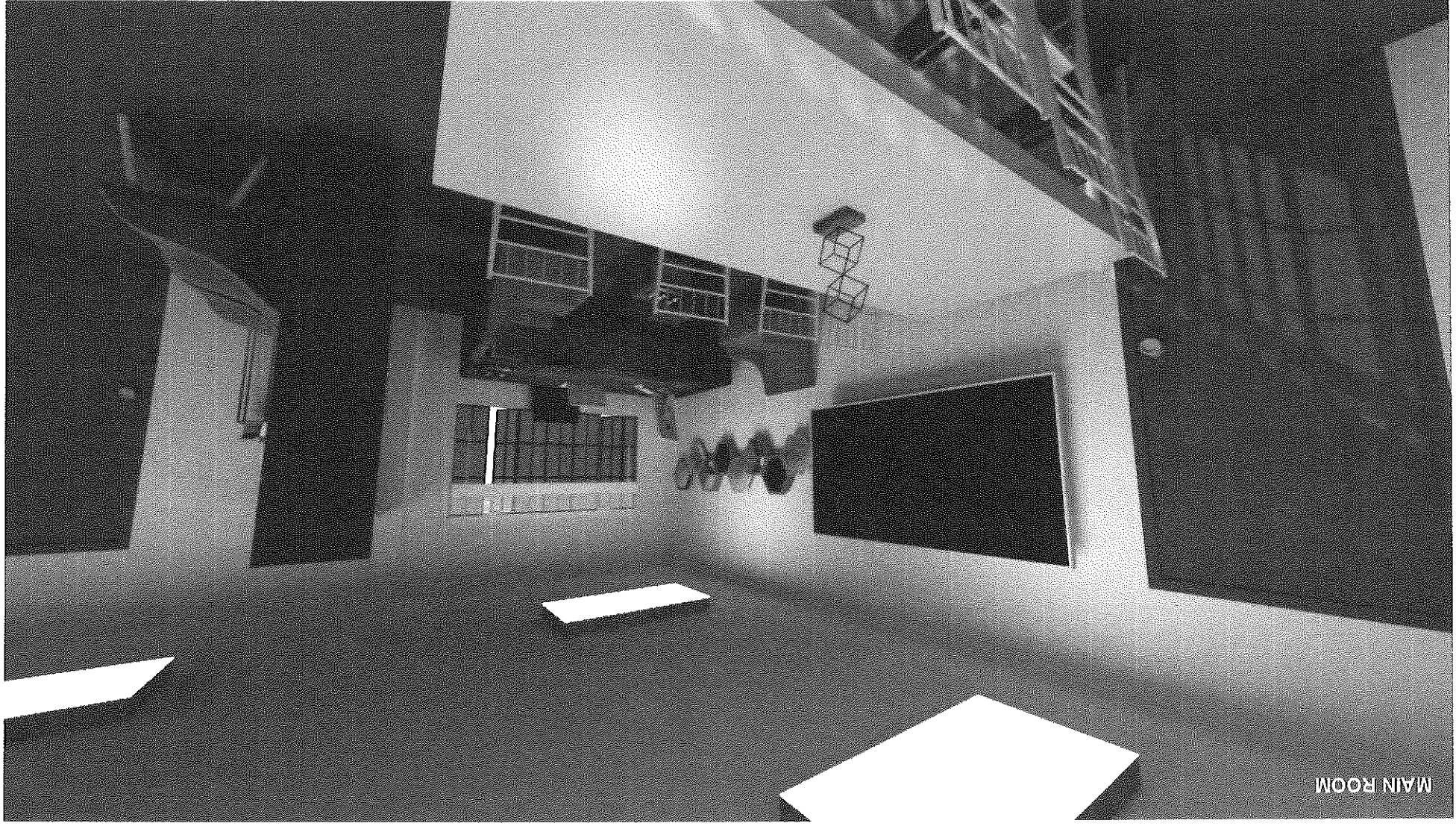
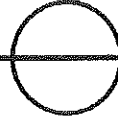

MAIN ROOM

PERSPECTIVE

ACS

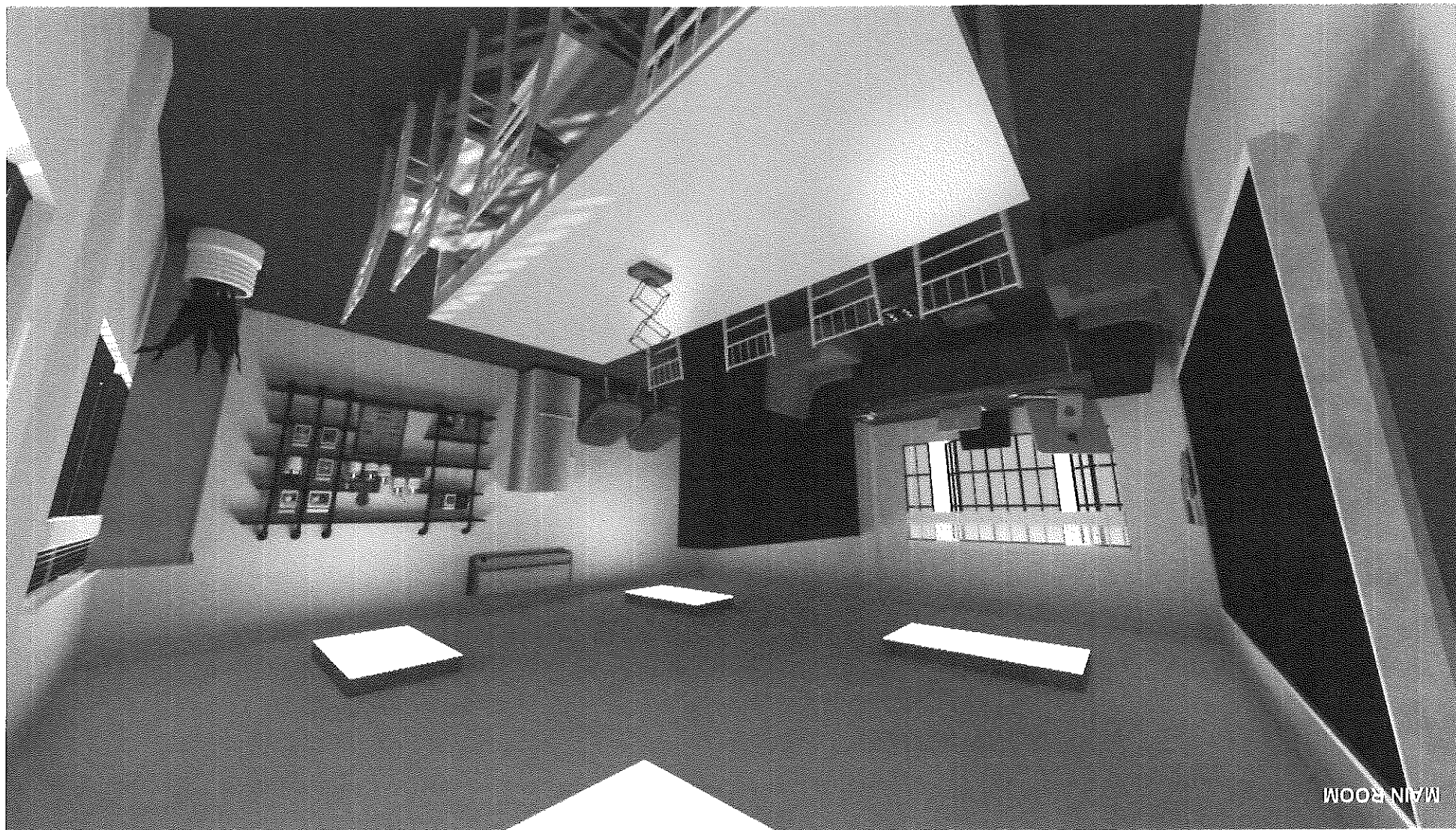
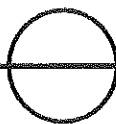

MAIN ROOM

ACS

PERSPECTIVE



STORAGE ROOM